

Spoolmatic 15A/30A Hook-Up Recommendations

CV Power Supply	Spoolmatic 15A/30A
Millermatic® Vintage*	Need Module #043 084
Millermatic®DVI™ and 210	Need Adapter Cable #195 287 (WFS controlled at machine)
Millermatic®250X*, 251, 300 w/meters*, 350/350P	Direct Hook-Up
Regency® 250*, CP Series, Shopmaster™, XMT®, Deltaweld®, Dimension™ Series	Need WC-24 #137 549
Bobcat Series Miller Legend® 302	Need WC-24 #137 546-01-1
Trailblazer®275 DC, 302, Trailblazer®Pro 350 D, PipePro™	Need WC-24 #137 549

*Discontinued product.

Spoolmatic to Welder Hook-Up

Note: Cords and cables are supplied unless noted otherwise on drawings below. Refer to Owner's Manual for complete installation instructions.

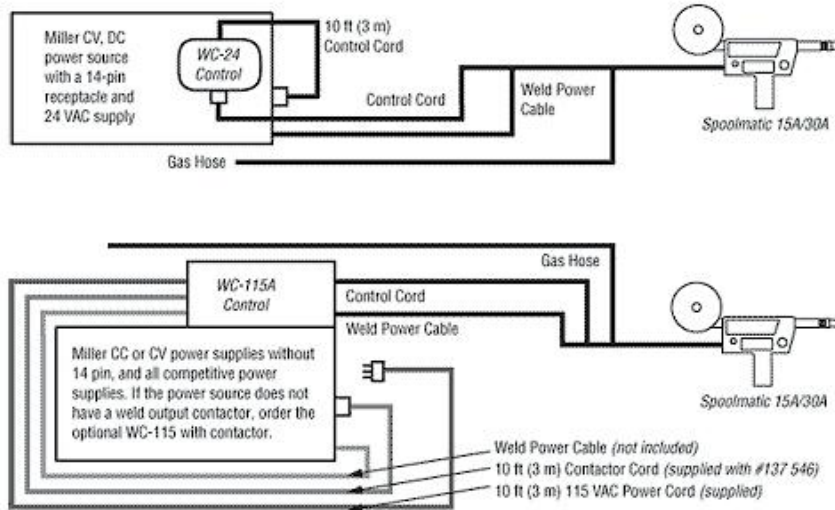

To connect the Spoolmatic 15A or 30A and WC-24 control to older-style Miller or competitive CV power sources that do not have a 24 VAC supply, the PSA-2 control #141 604 is required.

To connect the Spoolmatic 15A or 30A and WC-24 control to Millermatic® 200 and Spoolmate™ 200 power sources that have a 4-pin receptacle, order adapter cord #042 236.

To connect the WC-115A control to older-style Miller power sources having Hubbell or 5-pin contactor control receptacles, the appropriate connector must be ordered separately:

To connect to older-style Miller CC power sources having a two-socket Hubbell connector, order plug #039 618.

If Miller power source has a 5-pin receptacle, order #039 273 and #039 685 and install on WC-115 control cord.

To connect to older-style Miller CV power sources having a two-prong Hubbell connector, order plug #039 635.

Note: These connectors are to replace 14-pin connector on 10 ft interconnect contactor cord.